

# Nitrogen Dioxide (NO<sub>2</sub>) Analog Gas Transmitters



## DESCRIPTION

Microprocessor-based analog gas transmitter for the detection of nitrogen dioxide (NO<sub>2</sub>)/diesel fumes in the ambient air.

## APPLICATION

To sense nitrogen dioxide (NO<sub>2</sub>) in a wide variety of commercial and industrial applications such as vehicle diesel exhaust in parking structures, engine repair shops, tunnels, equipment rooms and ventilation systems, etc. and transmit to any compatible electronic analog control, DDC/PLC control or automation system.

## FEATURES

- Continuous monitoring
- (0)4-20 mA, (0)2-10 VDC output, selectable
- Polarity protected
- Two-stage relay output control, optional
- Digital display, optional
- Electrochemical gas sensor, gas specific
- Temperature compensated
- Easy plug-in sensor
- RFI/EMI protected
- Modular plug-in technology
- Easy maintenance



**PolyGard  
AT-1130 V3**



NRTL Certification to STD  
**UL 61010-1**  
"Pending"

## SPECIFICATIONS

### Electrical

Power supply	24 VAC ± 15%, 50/60 Hz, or 17-28 VDC, polarity protected
Power consumption	22 mA (0.6 VA), max.
- w/relay package	35 mA (1.0 VA), max.
- w/heater	235 mA (6 VA), max.
RFI/EMI protection	5.0 W @ 1 ft. (0.31 m) radiated

### Sensor Performance

Gas detected	Nitrogen dioxide (NO <sub>2</sub> )
Sensor element	Electrochemical, diffusion
Range	Span selectable from 0-10 to 0-20 ppm via calibration, 0-10 ppm factory set
Stability & resolution	± 0.1 ppm of reading
Repeatability	± 2% of reading
Long term output drift	< 2% signal loss/month
Response time	t <sub>90</sub> < 60 sec.
Sensor life expectancy	2 years, normal operating environment
Sensor coverage	4,000 sq.ft., max. 6,000 sq.ft. (372 m <sup>2</sup> , max. 558 m <sup>2</sup> ), under "ideal conditions"

### Installation Location

Mounting height	1 to 3 ft (0.3 to 1.0 m) above floor for standard garage applications, consult with factory for other applications
-----------------	--

### Type of Control

General	Continuous proportional analog sensor signal output
Analog output	(0)4-20 mA, load < 500 Ω; (0)2-10 VDC, load > 50K Ω; jumper selectable, polarity protected
Optional contact outputs	(2) relays, potential free

### Environmental

Permissible ambient	
- working temperature	14°F to 104°F (-10°C to 40°C)
- storage temperature	-4°F to 104°F (-20°C to 40°C)
- humidity	15 to 95% RH, non condensing
- working pressure	Atmospheric ± 10%

### Physical

Enclosure, standard	
- material	Galvanized steel w/zinc coating, corrosion resistant
- color	Light gray
- protection	NEMA 1 (IP42), general purpose
- installation	Wall (surface) mounted, or single gang electrical box
Dimensions (H x W x D)	5.59 x 5.59 x 2.48 in. (142 x 142 x 63 mm)
Cable entry	1 hole for 1/2 in. conduit for wall (surface) mounting, and 1 hole on back side of base plate for single gang electrical box mounting

**SPECIFICATIONS**

<b>Physical (cont...)</b>	
Wire connection	Terminal blocks, screw type for lead wire
Wire size	Min. 24 AWG (0.25 mm <sup>2</sup> ), Max. 14 AWG (2.5 mm <sup>2</sup> )
Wire distance	Max. loop resistance 450 Ω (= wire resistance plus controller input resistance)
Weight	0.7 lbs. (0.3 kg)
<b>Calibration</b>	
	Adjustment via onboard zero and gain potentiometers
<b>Approvals/Listings</b>	
- unit rating	NRTL Certification to STD ANSI/UL 61010-1 – “Pending” CE EMV-Compliance 2004/108/EWG, low voltage directives 73/23/EWG
<b>Warranty</b>	
	Two years material and workmanship, 12 months normal exposure for sensor element

**OPTIONS**

<b>Digital Display</b>	Liquid crystal display “LCD”, w/o backlight, two lines, 16 characters, 1/10 digit resolution
Display	NO <sub>2</sub> ppm values
Permissible ambient	
- working temperature	-4°F to 158° (-20°C to 70°C)
<b>Enclosures</b>	
<b>Duct mounted “1”</b>	
- w/probe	NEMA 3 (IP45) 7/8 in. (22 mm) diameter and 7.16 in. (182 mm) length
- cable entry	1 hole for 1/2 in. conduit
<b>Wall mounted “A”</b>	
- material	NEMA 12 (IP55) Polycarbonate, UL 94-HB, fire-retardant
- conformity	UL 50
- color	Light gray
- installation	Wall (surface) mounted, or single gang electrical box
- dimensions (H x W x D)	5.12 x 3.70 x 2.25 in. (130 x 94 x 57 mm)
- cable entry	1 hole for 1/2 in. conduit for wall (surface) mounting, and 1 hole on back side of base plate for single gang electrical box mounting
- enclosure approval	UL Listed, E208470 CSA Certified, E208470

**OPTIONS**

<b>Wall mounted “C”</b>	
- material	NEMA 4X (IP65) Polycarbonate, UL 94-HB, fire-retardant
- conformity	UL 50
- color	Light gray
- gas inlet	Special moisture filter protection
- installation	Wall (surface) mount
- dimensions (H x W x D)	5.12 x 5.12 x 2.95 in. (130 x 130 x 75 mm)
- cable entry	(1) PG 13.5 compression fitting, removeable, hole fits 1/2 in. conduit conductor
- enclosure approval	UL Listed, E208470 CSA Certified, E208470
<b>Wall mounted “4”</b>	
- material	NEMA 4X (IP65), w/splash guard
- color	ABS UL94V0 Light gray
- installation	Wall (surface) mount
- dimensions (H x W x D)	4.80 x 4.72 x 3.42 in. (122 x 120 x 87mm)
- cable entry	(1) PG 13.5 compression fitting, removeable, hole fits 1/2 in. conduit conductor
<b>Relay Package</b>	
Type	(1) SPDT (R1), and (1) SPST-NC or SPST-NO (R2), jumper selectable
Contact rating	30 VAC/VDC, 0.5 A, max.
Setpoint (factory set)	Lo/SPDT = 2 ppm* Hi/SPST = 5 ppm*
Switching differential (factory set)	0.5 ppm* * other values on special request at time of ordering
Relay mode (factory set)	De-energized for each relay, energized (fail-safe) mode on special request
Status indicator	(2) LEDs, one for each relay
Relay approval	UL Recognized, E41515 CSA, C22.2 No. 0, No. 14 (File No. LR31928)
<b>Heater, built-in</b>	
Ambient temperature	For low temperature environment
Power consumption	-40°F (-40°C)
Thermostatic control	0.2 A (5 VA), max. 32°F (0°C) ± 5°F (3°C)

**ORDERING INFORMATION**

**AT-1130 - 0 - 000 - 1** (Product label "AT-1130-x-xxx-x V3")

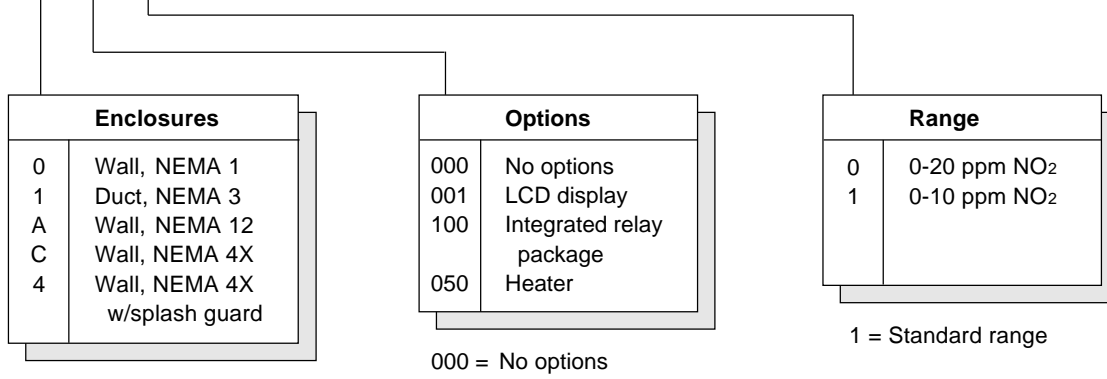

**WIRING CONFIGURATION**

**AT-1130**  
**4-20 mA signal, 2-wire, loop-powered, 24 VDC**

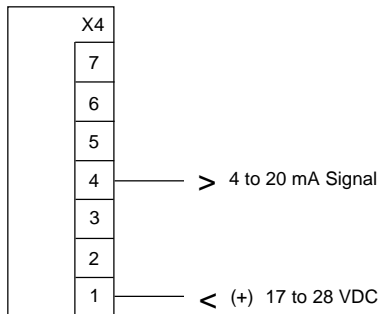

**AT-1130**  
**(0)2-10 VDC signal, 3-wire, 24 VAC or 24 VDC**

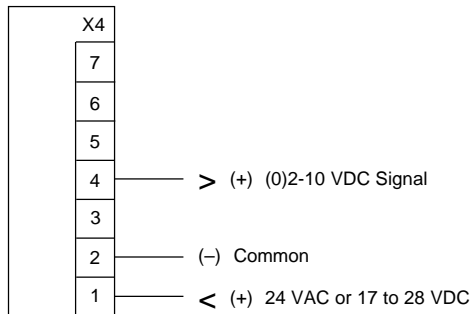

**AT-1130**  
**(0)4-20 mA signal, 3-wire, 24 VAC or 24 VDC\*\***

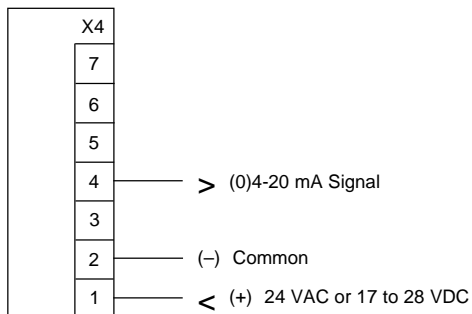

Jumper output signal range selectors:

- V-A Over both pins = VDC  
Pins not covered = mA
- 0-20% Over both pins = 4-20 mA / 2-10 VDC  
Pins not covered = 0-20 mA / 0-10 VDC

Notes:

*2-wire loop-powered wire configuration allow only 4-20 mA signal.*

Signal range jumper selection:

- V-A Pins not covered
- 0-20% Pins both covered

**Optional relay package**  
**(0)4-20 mA signal, 3-wire, 24 VAC or 24 VDC\*\***

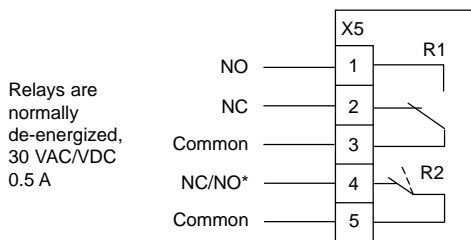

**\*\* For (0)4-20 mA signal with optional relay package, LCD and/or heater, the 3-wire configuration must be applied.**

*Twisted, shielded wire is recommended for 2- or 3-wire configurations.*

*Shield should be grounded only at the controller. DO NOT ground shield at both ends!*

**With optional heater:**

*The wiring must be sized appropriately for a power of 0.3 A, 24 VDC.*

\*Jumper SPST relay NC/NO selector:

- NC Covers top two pins = SPST-NC
- NO Covers bottom two pins = SPST-NO

Note: *When using AT-1130 transmitter w/relay package as a stand-alone unit (no connection to a controller), pins on jumpers "V-A" and "0-20%" must be covered.*

*See Jumper output signal range selectors.*